

Product sheet

Miniature connector



Product	Contacts: 5 Stereo, Male angled connector, shieldable, cable outlet 6 - 8 mm, with UL approval	Area	M16 IP67 Series 423
Pole	5 Stereo	Article number	99 5617 75 05

Illustration



Scale drawing

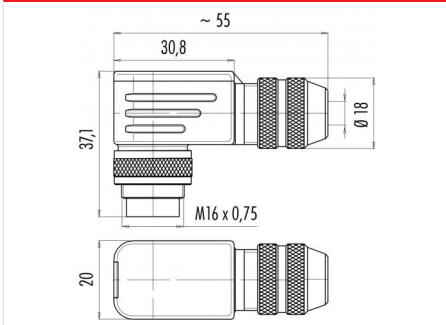

Contact Arrangement

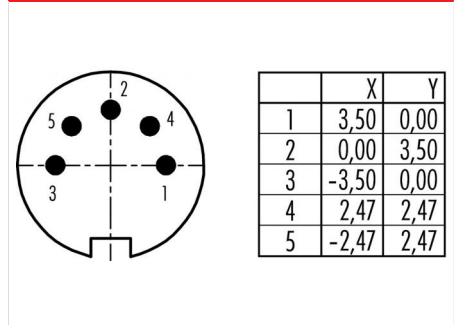

Attenuation characteristic

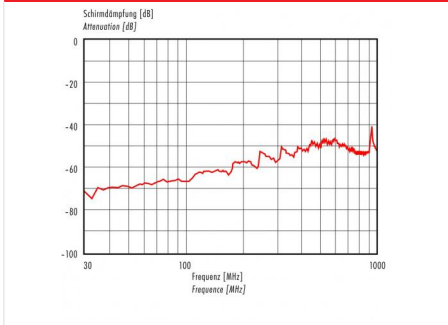

You can find the item description and assembly instruction on the next page.

Technical data

Common values

Connector Design	Male angled connector
Connector locking system	screw
Termination	Solder
Wire gauge (mm)	0.75 mm ²
Wire gauge (AWG)	20
Cable outlet	6 - 8 mm
Upper temperature	95 °C
Lower temperature	-40 °C

Electrical values

Rated voltage	60 V
Rated impulse voltage	500 V
Pollution degree	1
Overvoltage category	I
Material group	III
Rated current (40°C)	6 A
Volume resistivity	≤ 5 mΩ
EMV compliance	shielded
Degree of protection	IP67
Mechanical operation	> 500 mating cycles

Material

Material of contact	CuZn (Brass)
Contact plating	Ag (Silver)
Material of contact body	PBT (UL 94 V-0)
Material of housing	CuZn (Brass nickel-plated)

Contacts: 5 Stereo, Male angled connector, shieldable, cable outlet 6 - 8 mm, silver plated contacts, with UL approval



Product

Contacts: 5 Stereo, Male angled connector, shieldable, cable outlet 6 - 8 mm, with UL approval
5 Stereo

Area
Article number

M16 IP67 Series 423
99 5617 75 05

Pole

Item description

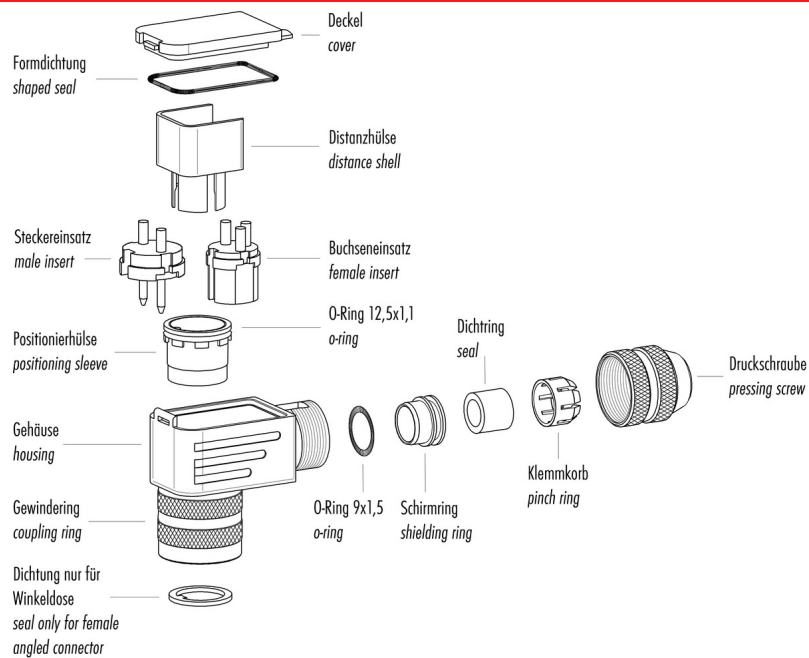

Installation instructions / Mounting cutout

Winkelversion

1. Dichtungen montieren (3x).
2. Kabelteile auffädeln.
3. Kabel und Schirm abmanteln.
4. Litzen durch das Gehäuse fädeln.
5. Schirmring, Klemmkorb montieren.
6. Druckschraube leicht andrehen.
7. Litzen an Kontakteinsatz löten.
8. Verdrehhülse in Winkelstellung montieren.
9. Kontakteinsatz, Distanzhülse einsetzen.
10. Deckel einhaken.
11. Druckschraube festziehen (ca. 10-20 Nm).

Angled version

1. Assemble sealing rings (3x).
2. Bead cable parts.
3. Dismantle cable and shielding braid.
4. Push single wires through housing.
5. Mount shielding ring and pinch ring.
6. Slightly fix pressing screw.
7. Solder wires to insert.
8. Mount positioning sleeve in angled position.
9. Put in insert and distance sleeve.
10. Mount lid.
11. Fix pressing screw (approx. 10-20 Nm).

