

# Product sheet

## Output connector



Product Pole	<b>Contacts: 24, Female angled connector</b> <b>24</b>	Area Article number	<b>RD30 Power Series 694</b> <b>99 0738 72 24</b>
--------------	---	---------------------	--

### Deratingkurven

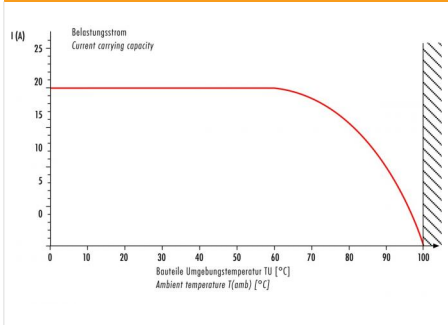

### Illustration



### Scale drawing

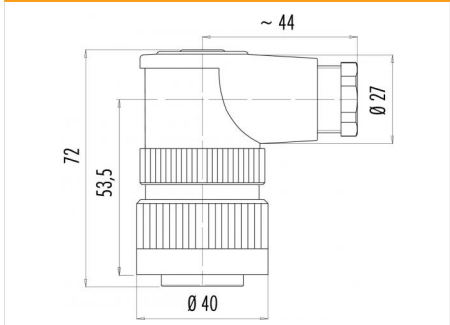

### Contact Arrangement

	X	Y
1	-5,25	-6,60
2	-1,75	-6,60
3	1,75	-6,60
4	5,25	-6,60
5	7,00	-3,10
6	3,50	-3,10
7	0,00	-3,10
8	-3,50	-3,10
9	-7,00	-3,10
10	-8,75	0,40
11	-5,25	0,40
12	-1,75	0,40
13	1,75	0,40
14	5,25	0,40
15	8,75	0,40
16	7,00	3,90
17	3,50	3,90
18	0,00	3,90
19	-3,50	3,90
20	-7,00	3,90
21	-5,25	7,40
22	-1,75	7,40
23	1,75	7,40
24	5,25	7,40

You can find the item description on the next page.

## Technical data

### Common values

Connector Design	Female angled connector
Connector locking system	screw
Termination	Solder
Wire gauge (mm)	0.25 mm <sup>2</sup>
Wire gauge (AWG)	24
Cable outlet	12 - 14 mm
Upper temperature	100 °C
Lower temperature	-40 °C

### Electrical values

Rated voltage	125 V
Rated impulse voltage	2500 V
Pollution degree	3
Overvoltage category	III
Material group	III
Rated current (40°C)	3 A
Volume resistivity	≤ 3 mΩ
EMV compliance	not shielded
Degree of protection	IP65
Mechanical operation	> 500 mating cycles

### Material

Material of contact	CuSn (Bronze)
Contact plating	Au (Gold)
Material of contact body	PA (UL 94 HB)
Material of housing	PA (UL 94 V-0)

Contacts: 24, female angled connector, cable outlet 12 - 14 mm

Product  
 Pole

**Contacts: 24, Female angled connector**  
**24**

Area  
 Article number

**RD30 Power Series 694**  
**99 0738 72 24**

### Item description

1. Winkelkappe, Winkelhülse, Dichtung, Klemmkorb und Druckschraube auffühen.
2. Kontakteinsatz in Gehäuse einclippen.
3. Leiter abmanteln, abschleifen und anschließen.
4. Winkelhülse mit vormontiertem Gehäuse bis zum mechanischen Anschlag fest verschrauben.
5. Teile gemäß Darstellung montieren.

1. Bead angled hood, sleeve, seal, pinch ring and pressing screw.
2. Clip contact insert into housing.
3. Dismantle cable, strip wire and contact wires.
4. Strongly fasten angled sleeve with preassembled housing up to mechanical stop.
5. Mount remaining parts according to figure.

