

Product sheet

Output connector

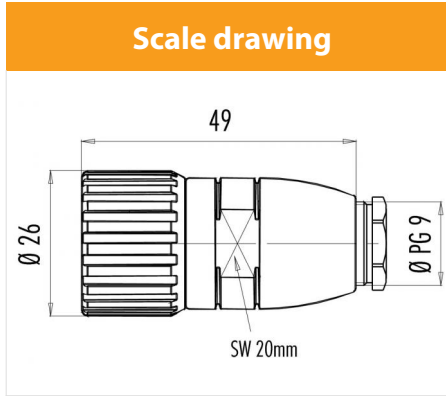

Product	Contacts: 12, Female cable connector, (the pin and socket insert counter-rotate in right and left turning models)	Area	M23 Power Series 623
Pole	12	Article number	99 4606 10 12



Contact Arrangement

	X	Y
1	3,60	4,30
2	5,55	1,00
3	4,90	-2,80
4	1,90	-5,30
5	-1,90	-5,30
6	-4,90	-2,80
7	-5,55	1,00
8	-3,60	4,30
9	0,00	4,50
10	1,90	1,00
11	0,00	-2,20
12	-1,90	1,00

You can find the assembly instruction on the next page.

Technical data

Common values

Connector Design	Female cable connector
Connector locking system	screw
Termination	Solder
Wire gauge (mm)	1.00 mm ²
Wire gauge (AWG)	18
Cable outlet	6 - 10 mm
Upper temperature	125 °C
Lower temperature	-20 °C

Electrical values

Rated voltage	150 V
Rated impulse voltage	1500 V
Pollution degree	3
Overvoltage category	II
Material group	III
Rated current (40°C)	8 A
Volume resistivity	≤ 3 mΩ
EMV compliance	not shielded
Degree of protection	IP67
Mechanical operation	> 50 mating cycles

Material

Material of contact	CuSn (Bronze)
Contact plating	Au (Gold)
Material of contact body	PBT/PA66
Material of housing	CuZn (Brass nickel-plated)

Contacts: 12, Female cable connector, left-turning

Product

Contacts: 12, Female cable connector, (the pin and socket insert counter-rotate in right and left turning models)

Area

M23 Power Series 623

Article number

99 4606 10 12

Pole

12

Installation instructions / Mounting cutout

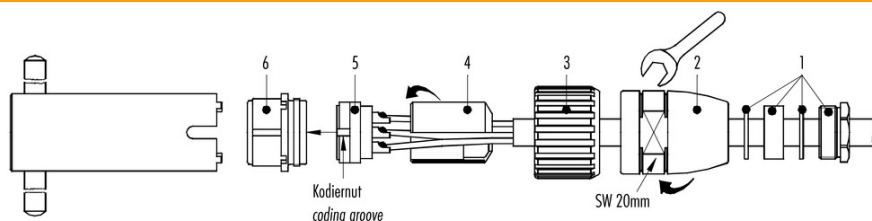

- Kabelverschraubung Pos. 1, Adapter Pos. 2 und Überwurfmutter Pos. 3 auf das Kabel schieben.
- Kabel-Außenmantel 20 mm abisolieren.
- Folie, Füller und innere Isolierungen abschneiden.
- Litzen 3,5 mm abisolieren, verdrehen und verzinnen.
- Litzen an Kontakte löten, crimpen oder schrauben.
- Distanzhülse Pos. 4 einfügen.
- Einsatz Pos. 5 und Distanzhülse Pos. 4 in Einsatzring Pos. 6 einführen. Hierbei ist zu beachten, daß die gewünschte Kodiernut des Einsatzes Pos. 6 in den Kodiersteg eingeführt wird.
- Adapter Pos. 2 Festschrauben auf Anschlag.
- Kabelverschraubung Pos. 1 Festschrauben.

Anzugsdrehmoment für Klemmschraube Kontakteinsatz Pos. 5 mit Schraubkontakten beachten:

- max. 0,1 Nm für Schraubkontakte Steckdurchmesser 1 mm
- max. 0,2 Nm für Schraubkontakte Steckdurchmesser 2 mm

- Push the cable screw connection (1), adapter (2) and coupling nut (3) onto the cable.
- Strip the cable coating by 20 mm.
- Trim foil, filler and inner insulation.
- Strip the single wires by 3.5 mm, twist and tin.
- Solder, crimp or screw the single wires to the contacts.
- Insert the distance shell (4).
- Guide the insert (5) and distance shell (4) into the insert ring (6), mind that the desired coding groove of the insert (6) is pushed into the coding bar.
- Screw the adapter (2) as tight as possible.
- Screw the cable gland (1) as tight as possible.

Please note: torque for clamping screw for contact insert (5) with screw contacts:

- max. 0.1 Nm for screw contacts with mating dia. 1 mm
- max. 0.2 Nm for screw contacts with mating dia. 2 mm