

# Product sheet

## Output connector

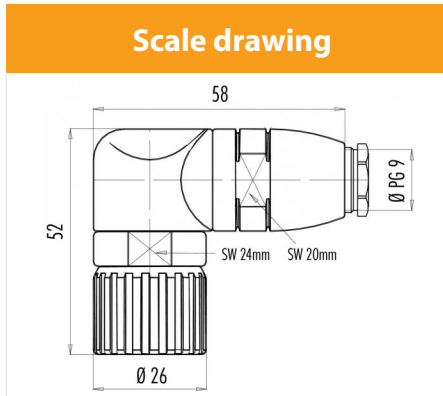

Product	<b>Contacts: 19, Male angled connector, right-turning (the pin and socket insert counter-rotate in right and left turning models)</b>	Area	<b>M23 Power Series 623</b>
Pole	<b>19</b>	Article number	<b>99 4631 70 19</b>



### Contact Arrangement

	X	Y
1	3,00	5,20
2	5,20	3,00
3	6,00	0,00
4	5,20	-3,00
5	3,00	-5,20
6	0,00	-6,00
7	-3,00	-5,20
8	-5,20	-3,00
9	-6,00	0,00
10	-5,20	3,00
11	-3,00	5,20
12	0,00	6,00
13	2,75	1,60
14	2,75	-1,60
15	0,00	-3,00
16	-2,75	-1,60
17	-2,75	1,60
18	0,00	3,00
19	0,00	0,00

You can find the assembly instruction on the next page.

## Technical data

### Common values

Connector Design	Male angled connector
Connector locking system	screw
Termination	Solder
Wire gauge (mm)	16x1.0/ 3x1.5 mm <sup>2</sup>
Wire gauge (AWG)	16x18/ 3x16
Cable outlet	6 - 10 mm
Upper temperature	125 °C
Lower temperature	-20 °C

### Electrical values

Rated voltage	150 V
Rated impulse voltage	1500 V
Pollution degree	3
Overvoltage category	II
Material group	III
Rated current (40°C)	16x8A/ 3x10A
Volume resistivity	≤ 3 mΩ
EMV compliance	not shielded
Degree of protection	IP67
Mechanical operation	> 50 mating cycles

### Material

Material of contact	CuZn (Brass)
Contact plating	Au (Gold)
Material of contact body	PBT/PA66
Material of housing	CuZn (Brass nickel-plated)

Contacts: 19, Male angled connector, right-turning

Product

**Contacts: 19, Male angled connector, right-turning (the pin and socket insert counter-rotate in right and left turning models)**

Area

**M23 Power Series 623**

Article number

**99 4631 70 19**

Pole

**19**

## Installation instructions / Mounting cutout

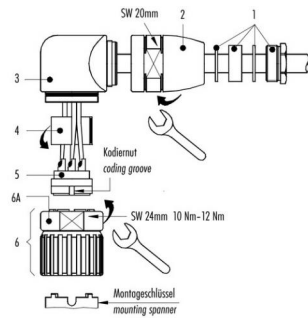

- Kabelverschraubung Pos. 1, Adapter Pos. 2 und Winkelkörper Pos. 3 auf des Kabel schieben.
- Kabel Außenmantel 30 mm abschleifen.
- Füll-, Füll- und innere Isolierungen abschneiden.
- Litzen 3,5 mm abschleifen, verdrehen und verzinnen.
- Litzen an Kontakte löten, crimpen oder schrauben.
- Distanzhülse Pos. 4 einfügen.
- Einsatz Pos. 5 und Distanzhülse Pos. 4 in Einheit Pos. 6 einführen. Hierbei ist zu beachten, daß die gewünschte Kodiernut des Einsatzes Pos. 5 in den Kodiersteg eingeführt wird.
- Gesamte Einheit in Winkelkörper einführen (Achtung: acht Kodiernutmöglichkeiten) und mit Mutter Pos. 6A sichern (Anzugsdrehmoment: 10 Nm bis 12 Nm).
- Adapter Pos. 2 Festschrauben auf Anschlag.
- Kabelverschraubung Pos. 1 Festschrauben.

Anzugsdrehmoment für Klemmschraube Kontakteinsatz Pos. 5 mit Schraubkontakten beachten:  
 • max. 0,1 Nm für Schraubkontakte Steckdurchmesser 1 mm  
 • max. 0,2 Nm für Schraubkontakte Steckdurchmesser 2 mm

- Push the cable screw connection (1), adapter (2) and angled housing (3) onto the cable.
- Strip the cable coating by 30 mm.
- Trim foil, filler and inner insulation.
- Strip the single wires by 3,5 mm, twist and tin.
- Solder, crimp or screw the single wires to the contacts.
- Insert the distance shell (4).
- Guide the insert (5) and distance shell (4) into the unit (6), mind that the desired coding groove of the insert (5) is pushed into the coding bar.
- Insert the entire unit into the angle housing (Attention: eight coding options) and secure with nut (6A) (torque: 10 Nm up to 12 Nm).
- Screw the adapter (2) as tight as possible.
- Screw the cable gland (1) as tight as possible.

Please note: torque for clamping screw for contact insert (5) with screw contacts:  
 • max. 0,1 Nm for screw contacts with mating dia. 1 mm  
 • max. 0,2 Nm for screw contacts with mating dia. 2 mm