

Product	<b>Contacts: 4, Female cable connector with insulation displacement connection, gold contact plating</b>	Area	<b>M12-A Series 713</b>
Pole	<b>4</b>	Article number	<b>99 0528 12 04</b>

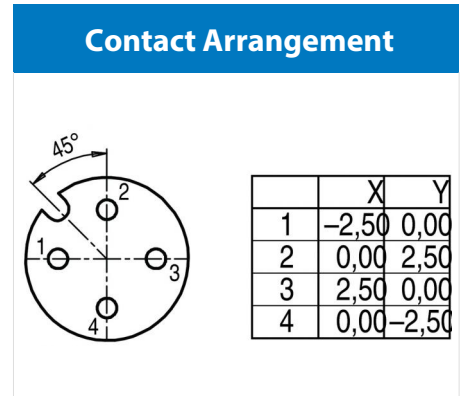
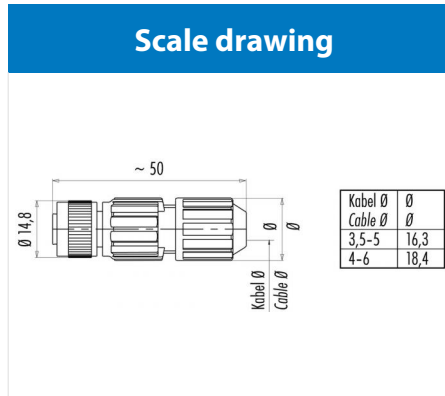

You can find the assembly instruction on the next page.

## Technical data

### Common values

Connector Design	Female cable connector
Connector locking system	screw
Termination	Screw terminal
Wire gauge (mm)	0.34 - 0.75 mm <sup>2</sup>
Cable outlet	4 - 8 mm
Upper temperature	80 °C
Lower temperature	-40 °C

### Electrical values

Rated voltage	250 V
Rated impulse voltage	2500 V
Pollution degree	3
Overvoltage category	II
Material group	III
Rated current (40°C)	4 A
Volume resistivity	≤ 3 mΩ
EMV compliance	not shielded
Degree of protection	IP67
Mechanical operation	> 100 mating cycles

### Material

Material of contact	CuZn (Brass)
Contact plating	Au (Gold)
Material of contact body	PA
Material of housing	CuZn nickel-plated, PA

Contacts: 4, Female cable connector with insulation displacement connection, gold contact plating, cable outlet: 0.34 - 0.75 mm Ø 4 - 8

Product

**Contacts: 4, Female cable connector with insulation displacement connection, gold contact plating**

Area  
Article number

**M12-A Series 713  
99 0528 12 04**

Pole

4

### Installation instructions / Mounting cutout

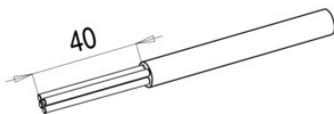

Ader-Ø incl. Isolation	Core-Ø incl. insulation	≤1,6mm
Kleinster Draht-Ø der Ader	Smallest wire-Ø of cores	0,5mm
Ø des Leitungsmantels	Ø of the conductor sheath	5,6mm
Aderisolation	Core insulation	PVC/PE
Anschlussstemperatur	Connecting temperature	5°C – +50°C
Anschlusshäufigkeit	Termination frequency	10

- |  |   |
|--|---|
| <ol style="list-style-type: none"> <li>1. Leitungsummantelung entfernen (ca. 40mm).</li> <li>2. Die Überwurfmutter bis zum Anschlag auf die Leitung aufstecken.</li> <li>3. Adern in die gekennzeichneten Aderführungen einrasten.</li> <li>4. Überstehende Aderenden bündig abschneiden.</li> <li>5. Überwurfmutter auf den Kontaktträger aufstecken und mit Drehmoment (1,2 Nm) anziehen.</li> </ol> | <ol style="list-style-type: none"> <li>1. Remove cable coating (approx. 40mm).</li> <li>2. Slide the union nut onto the conductor as far as it will go.</li> <li>3. Snap the cores into the marked core entries.</li> <li>4. Cut off the core ends so that there is no overhang.</li> <li>5. Push the cap nut onto the contact carrier and tighten with the necessary torque (1,2 Nm).</li> </ol> |
|--|---|

### Installation instructions / Mounting cutout

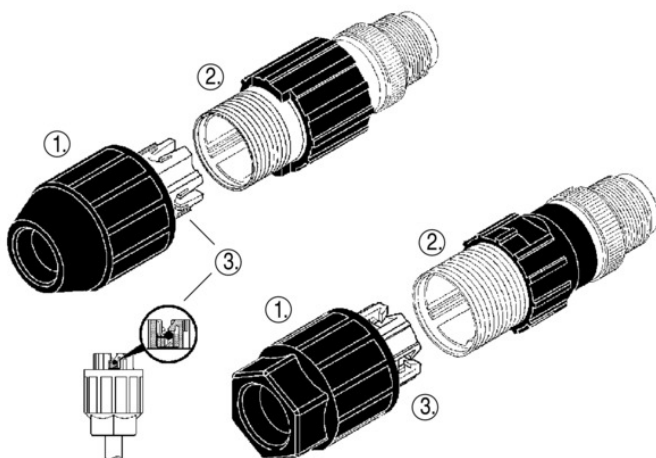

1. Vormontierte Überwurfmutterereinheit (Überwurfmutter, Dichtung, Spleißring mit Zugentlastungskrone)
  2. Kontaktträger
  3. Spleißring
- 
1. Premounted cup nut unit (cap nut, seal, splice ring with strain relief)
  2. Contact carrier
  3. Splice ring