

Product sheet

Subminiature connector



Product	Contacts 3, Cable plug connector IP 67, shielded	Area	Push-Pull IP67 Series 430
Pole	3	Article number	99 4905 00 03

Illustration	Scale drawing	Contact Arrangement												
		<table border="1" style="margin-left: auto; margin-right: auto;"> <thead> <tr> <th></th> <th>X</th> <th>Y</th> </tr> </thead> <tbody> <tr> <td>1</td> <td>1,55</td> <td>0,00</td> </tr> <tr> <td>2</td> <td>0,00</td> <td>1,55</td> </tr> <tr> <td>3</td> <td>-1,55</td> <td>0,00</td> </tr> </tbody> </table>		X	Y	1	1,55	0,00	2	0,00	1,55	3	-1,55	0,00
	X	Y												
1	1,55	0,00												
2	0,00	1,55												
3	-1,55	0,00												

You can find the item description and assembly instruction on the next page.

Technical data

Common values

Connector Design	Cable plug connector
Connector locking system	Push-Pull
Termination	Solder
Wire gauge (mm)	0.25 mm ²
Wire gauge (AWG)	24
Cable outlet	3.5 - 5 mm
Upper temperature	85 °C
Lower temperature	-40 °C

Cable data

material housing	-
Insulation single lead	-
Single lead structure	-
Conductor resistance	-

Electrical values

Rated voltage	125 V
Rated impulse voltage	1500 V
Pollution degree	2
Overvoltage category	I
Material group	II
Rated current (40°C)	4 A
Volume resistivity	≤ 5 mΩ
EMV compliance	shieldable
Degree of protection	IP67
Mechanical operation	> 500 mating cycles

Material

Material of contact	CuZn (Brass)
Contact plating	Au (Gold)
Material of contact body	PBT, PA
Material of housing	PA

Contacts: 3, Cable plug connector IP 67, shielded

Product
Pole

**Contacts 3, Cable plug connector IP 67,
shielded
3**

Area
Article number

**Push-Pull IP67 Series 430
99 4905 00 03**

Item description

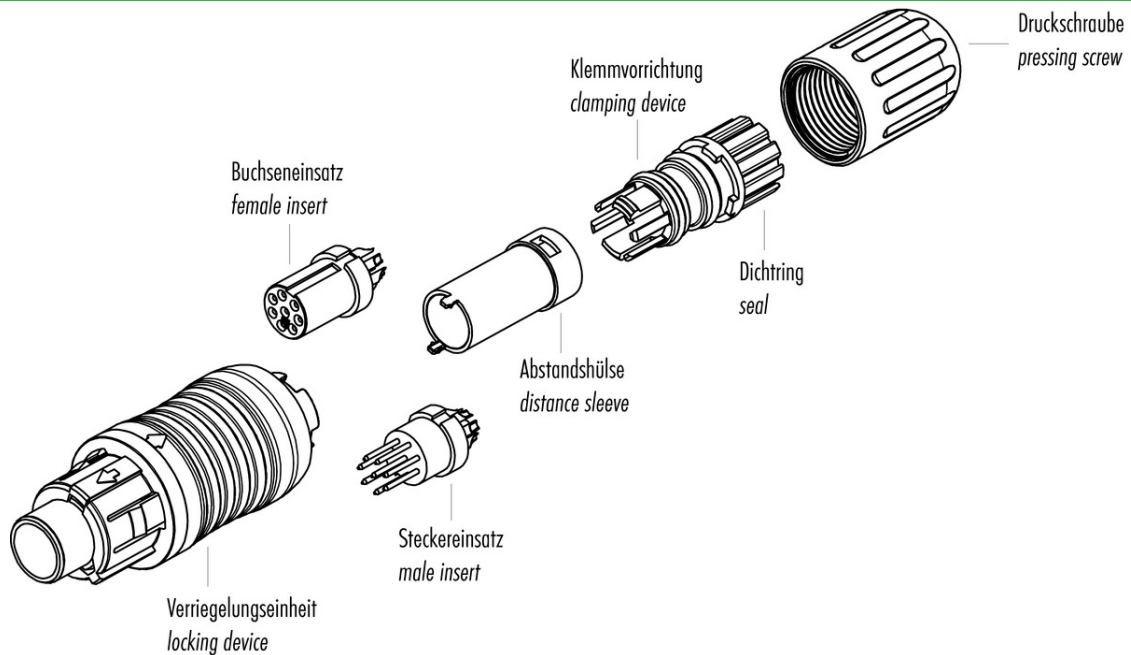

Installation instructions / Mounting cutout

1. Abmonteln auf L = 26mm.
Ummanelung nicht abstreifen.
2. Druckschraube und Dichtung am Kabel aufdrehen.
Dichtung in Klemmvorrichtung montieren.
Ummanelung entfernen.
3. Abschirmung aufzupflücken und auskämmen.
4. Litzen absichern und verzinnen.
5. Abstandshülse und Klemmvorrichtung vorstecken.
6. Einsätze anlöten.
7. Abstandshülse auf Hülse stecken.
8. Klemmvorrichtung verschieben und einrasten.
Die Abschirmhülse in der Krone rundherum einfädeln.
9. Abschirmhülse in Richtung Abschirmung abstreifen und kürzen.
zu lang: Litzen auf Dichtung - undicht
zu kurz: kein Kontakt zu Wellenring
10. Montierte Einheit in Trägerhülse stecken.
Druckschraube aufstecken und festziehen.

1. Strip to 26mm length but do not take off cable jacket.
2. Bend pressing screw and clamp device to cable.
Mount sealing ring to clamp device. Remove cable jacket.
3. Fan out and comb shielding braid.
4. Strip the insulation off the wires and tin them.
5. Snap in distance sleeve and clamp device.
6. Solder wires to solder cups.
7. Stick distance sleeve to sleeve.
8. Push forward and snap in clamp device.
Mount shielding braid around the crown.
9. Strip off and shorten shielding braid in the direction of the shielding ring.
too long: shielding braid on sealing ring - untight
too short: no contact to wave washer
10. Stick assembled unit into carrier sleeve and tighten pressing screw.

