

Product sheet

Output connector



Product
Pole

Polzahl: 9, Winkelstecker, rechtsdrehend
9

Area
Article number

M23 Power Series 623
99 4601 70 09

Illustration



Scale drawing

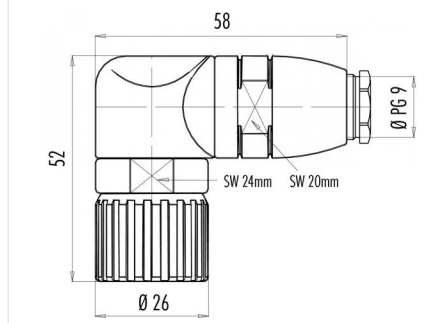

Contact Arrangement

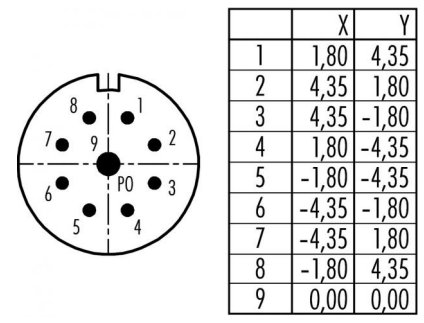

You can find the assembly instruction on the next page.

Technical data

Common values

Connector Design	Male angled connector
Connector locking system	screw
Termination	Solder
Wire gauge (mm)	8x1.5/ 1x2.5 mm ²
Wire gauge (AWG)	8x16/ 1x14
Cable outlet	6 - 10 mm
Upper temperature	125 °C
Lower temperature	-20 °C

Electrical values

Rated voltage	300 V
Rated impulse voltage	2500 V
Pollution degree	3
Overvoltage category	II
Material group	III
Rated current (40°C)	8x8A/ 1x20A
Volume resistivity	≤ 3 mΩ
EMV compliance	not shielded
Degree of protection	IP67
Mechanical operation	> 50 mating cycles

Material

Material of contact	CuZn (Brass)
Contact plating	Au (Gold)
Material of contact body	PBT/PA66
Material of housing	CuZn (Brass nickel-plated)

Contacts: 9, Male angled connector, right-turning

Product
Pole

Polzahl: 9, Winkelstecker, rechtsdrehend
9

Area
Article number

M23 Power Series 623
99 4601 70 09

Installation instructions / Mounting cutout

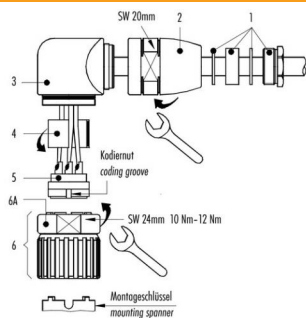

- Kabelverschraubung Pos. 1, Adapter Pos. 2 und Winkelkörper Pos. 3 auf des Kabel schieben.
- Kabel-Außenmantel 30 mm absollieren.
- Folie, Füller und innere Isolierungen abschneiden.
- Litzen 3,5 mm absollieren, verdrehen und verzinnen.
- Litzen an Kontakte löten, crimpen oder schrauben.
- Distanzhülse Pos. 4 einfügen.
- Einsatz Pos. 5 und Distanzhülse Pos. 4 in Einheit Pos. 6 einführen. Hierbei ist zu beachten, daß die gewünschte Kodelnut des Einsatzes Pos. 5 in den Kodersteg eingeführt wird.
- Gesamte Einheit in Winkelkörper einführen
(Achtung: acht Kodelmöglichekeiten) und mit Mutter Pos. 6A sichern
(Anzugsdrehmoment: 10 Nm bis 12 Nm).
- Adapter Pos. 2 Festschrauben auf Anschlag.
- Kabelverschraubung Pos. 1 Festschrauben.

Anzugsdrehmoment für Klemmschraube Kontakteinsatz Pos. 5 mit Schraubkontakten beachten:

- max. 0,1 Nm für Schraubkontakte Steckdurchmesser 1 mm
- max. 0,2 Nm für Schraubkontakte Steckdurchmesser 2 mm

- Push the cable screw connection (1), adapter (2) and angled housing (3) onto the cable.
- Strip the cable coating by 30 mm.
- Trim foil, filler and inner insulation.
- Strip the single wires by 3.5 mm, twist and tin.
- Solder, crimp or screw the single wires to the contacts.
- Insert the distance shell (4).
- Guide the insert (5) and distance shell (4) into the unit (6), mind that the desired coding groove of the insert (5) is pushed into the coding bar.
- Insert the entire unit into the angle housing
(Attention: eight coding options) and secure with nut (6A)
(torque: 10 Nm up to 12 Nm).
- Screw the adapter (2) as tight as possible.
- Screw the cable gland (1) as tight as possible.

Please note: torque for clamping screw for contact insert (5) with screw contacts:

- max. 0,1 Nm for screw contacts with mating dia. 1 mm
- max. 0,2 Nm for screw contacts with mating dia. 2 mm