

Product	Contacts: 4, Cable plug connector, with insulation displacement connection, gold contact plating	Area	M12-A Series 713
Pole	4	Article number	99 0527 14 04

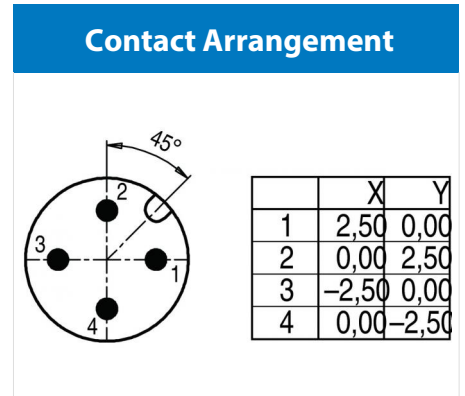
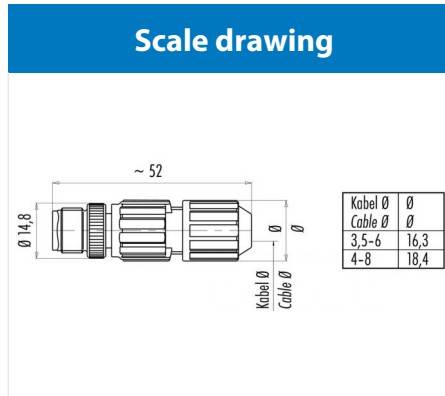

You can find the assembly instruction on the next page.

Technical data

Common values

Connector Design	Cable plug connector
Connector locking system	screw
Termination	Screw terminal
Wire gauge (mm)	0.14 - 0.34 mm ²
Cable outlet	4 - 8 mm
Upper temperature	80 °C
Lower temperature	-40 °C

Electrical values

Rated voltage	250 V
Rated impulse voltage	2500 V
Pollution degree	3
Overvoltage category	II
Material group	III
Rated current (40°C)	4 A
Volume resistivity	≤ 3 mΩ
EMV compliance	nicht geschirmt
Degree of protection	IP67
Mechanical operation	> 100 mating cycles

Material

Material of contact	CuZn (Brass)
Contact plating	Au (Gold)
Material of contact body	PA
Material of housing	CuZn / PA

Contacts: 4, Cable: 0.14 - 0.34 mm², Ø 3.5-6, cable plug connector, with insulation displacement connection, gold contact plating

Product

Contacts: 4, Cable plug connector, with insulation displacement connection, gold contact plating

Area
Article number

**M12-A Series 713
99 0527 14 04**

Pole

4

Installation instructions / Mounting cutout

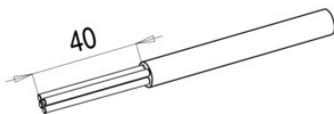

Ader-Ø incl. Isolation	Core-Ø incl. insulation	≤1,6mm
Kleinster Draht-Ø der Ader	Smallest wire-Ø of cores	0,5mm
Ø des Leitungsmantels	Ø of the conductor sheath	5,6mm
Aderisolation	Core insulation	PVC/PE
Anschlussstemperatur	Connecting temperature	5°C – +50°C
Anschlusshäufigkeit	Termination frequency	10

- | | |
|--|---|
| <ol style="list-style-type: none"> 1. Leitungsummantelung entfernen (ca. 40mm). 2. Die Überwurfmutter bis zum Anschlag auf die Leitung aufstecken. 3. Adern in die gekennzeichneten Aderführungen einrasten. 4. Überstehende Aderenden bündig abschneiden. 5. Überwurfmutter auf den Kontaktträger aufstecken und mit Drehmoment (1,2 Nm) anziehen. | <ol style="list-style-type: none"> 1. Remove cable coating (approx. 40mm). 2. Slide the union nut onto the conductor as far as it will go. 3. Snap the cores into the marked core entries. 4. Cut off the core ends so that there is no overhang. 5. Push the cap nut onto the contact carrier and tighten with the necessary torque (1,2 Nm). |
|--|---|

Installation instructions / Mounting cutout

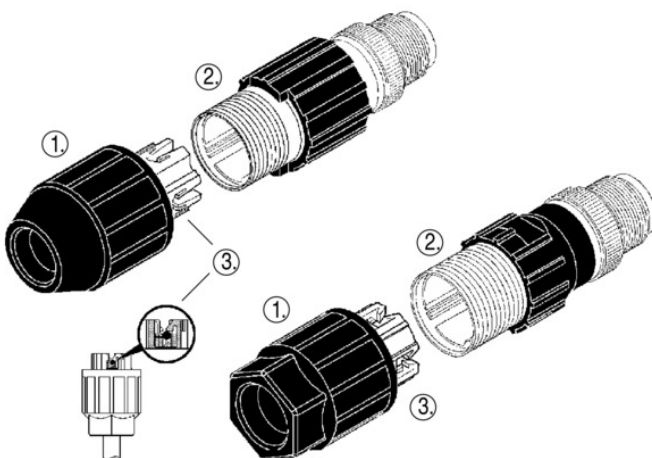

1. Vormontierte Überwurfmutterereinheit (Überwurfmutter, Dichtung, Spleißring mit Zugentlastungskrone)
 2. Kontaktträger
 3. Spleißring
-
1. Premounted cup nut unit (cap nut, seal, splice ring with strain relief)
 2. Contact carrier
 3. Splice ring