

Product sheet

Miniature connector



| | | | |
|---------|---|----------------|----------------------------|
| Product | Contacts: 4, cable plug connector with cable clamp, screw terminal connection, shieldable, cable outlet 6 - 8 mm | Area | M16 IP67 Series 423 |
| Pole | 4 | Article number | 99 5609 210 04 |

Illustration



Scale drawing

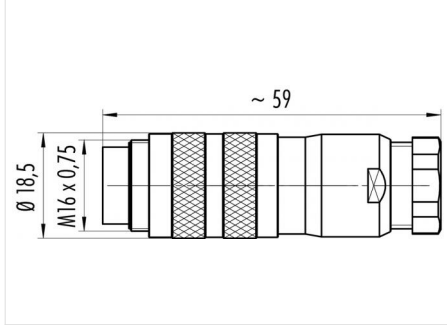

Contact Arrangement

| | X | Y |
|---|-------|-------|
| 1 | 3,32 | -1,08 |
| 2 | 2,05 | 2,83 |
| 3 | -2,05 | 2,83 |
| 4 | -3,32 | -1,08 |

Attenuation characteristic

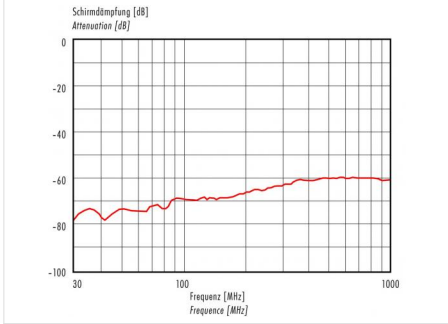

You can find the item description and assembly instruction on the next page.

Technical data

Common values

| | |
|--------------------------|----------------------------|
| Connector Design | Cable plug connector |
| Connector locking system | screw |
| Termination | Screwing |
| Wire gauge (mm) | 0.25 - 1.5 mm ² |
| Wire gauge (AWG) | 24 - 16 |
| Cable outlet | 6 - 7.8 mm |
| Upper temperature | 95 °C |
| Lower temperature | -40 °C |

Electrical values

| | |
|-----------------------|---------------------|
| Rated voltage | 250 V |
| Rated impulse voltage | 1500 V |
| Pollution degree | 1 |
| Overvoltage category | I |
| Material group | III |
| Rated current (40°C) | 6 A |
| Volume resistivity | ≤ 5 mΩ |
| EMV compliance | shielded |
| Degree of protection | IP67 |
| Mechanical operation | > 500 mating cycles |

Material

| | |
|--------------------------|----------------------------|
| Material of contact | CuZn (Brass) |
| Contact plating | Ag (Silver) |
| Material of contact body | PBT (UL 94 V-0) |
| Material of housing | CuZn (Brass nickel-plated) |

Contacts: 4, Cable plug connector with cable clamp, screw terminal connection, shieldable, cable outlet 6 - 8 mm, silver plated contacts

Product

Contacts: 4, cable plug connector with cable clamp, screw terminal connection, shieldable, cable outlet 6 - 8 mm

Area
Article number

**M16 IP67 Series 423
99 5609 210 04**

Pole

4

Item description

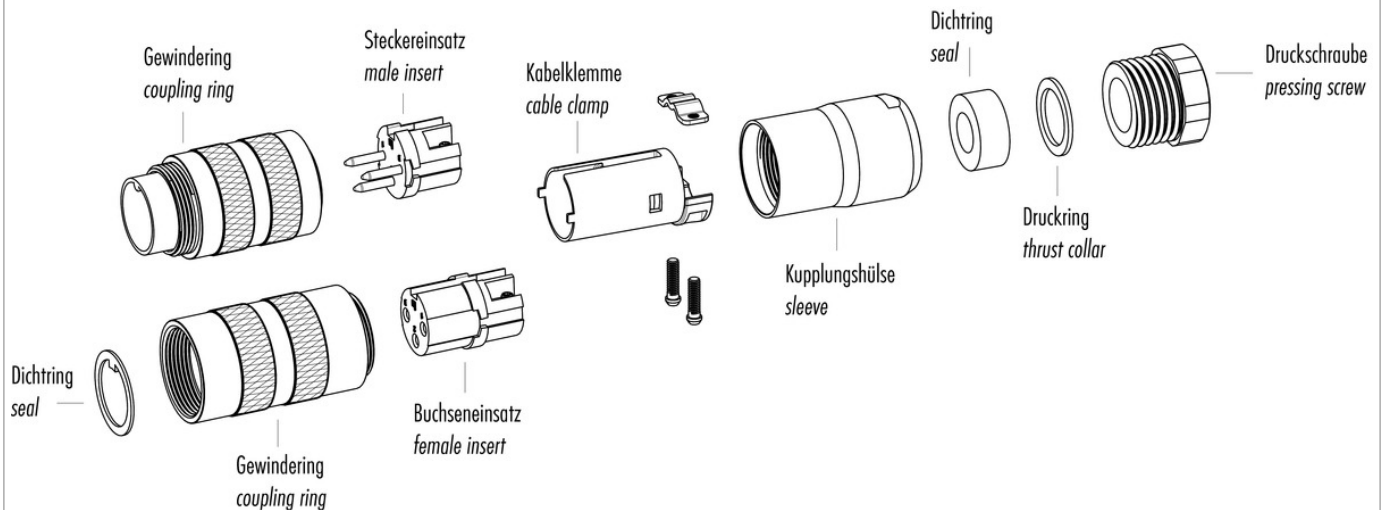

Installation instructions / Mounting cutout

Gerade Version

(Ausführung mit Schirmklemmring)

1. Druckschraube, Klemmkorb, Dichtung, Distanzhülse und ersten Schirmklemmring auffädeln.
2. Litzen abisolieren, Schirm aufweiten und zweiten Schirmklemmring auffädeln.
3. Litzen anlöten, Distanzhülse montieren, die beiden Klemmringe mit dem Schirm zusammenschieben und überstehenden Schirm abschneiden.
4. Übrige Teile gemäß Darstellung montieren.

Straight version

(Version with shield clamping ring)

1. Bead pressing screw, pinch ring, seal, distance shell and first shield clamping ring on cable.
2. Strip wires, widen shield and bead second shield clamping ring.
3. Solder wires, snap distance shell, push the two shield clamping rings together and cut off projecting shielding braid.
4. Assemble remaining parts according to picture.

